

Write your name here

Surname

Other names

Pearson Edexcel Certificate
Pearson Edexcel
International GCSE

Centre Number

--	--	--	--	--

Candidate Number

--	--	--	--	--

Mathematics A

Paper 2F



Foundation Tier

Monday 12 January 2015 – Afternoon
Time: 2 hours

Paper Reference
4MA0/2F
KMA0/2F

You must have:

Ruler graduated in centimetres and millimetres, protractor, compasses, pen, HB pencil, eraser, calculator. Tracing paper may be used.

Total Marks

Instructions

- Use **black** ink or ball-point pen.
- **Fill in the boxes** at the top of this page with your name, centre number and candidate number.
- Answer **all** questions.
- Without sufficient working, correct answers may be awarded no marks.
- Answer the questions in the spaces provided
– *there may be more space than you need.*
- **Calculators may be used.**
- You must **NOT** write anything on the formulae page.
Anything you write on the formulae page will gain NO credit.

Information

- The total mark for this paper is 100.
- The marks for **each** question are shown in brackets
– *use this as a guide as to how much time to spend on each question.*

Advice

- Read each question carefully before you start to answer it.
- Check your answers if you have time at the end.

Turn over ►

P44612A

©2015 Pearson Education Ltd.

5/5/11



PEARSON

International GCSE MATHEMATICS
FORMULAE SHEET – FOUNDATION TIER

Pythagoras' Theorem
 $a^2 + b^2 = c^2$

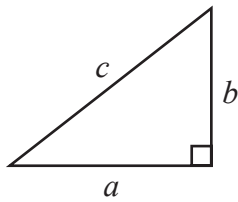

Area of a trapezium = $\frac{1}{2}(a + b)h$

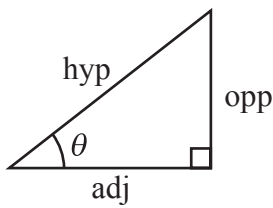
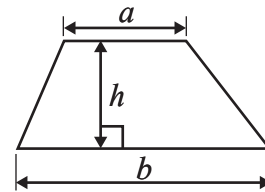

adj = hyp \times cos θ
opp = hyp \times sin θ
opp = adj \times tan θ

Volume of prism = area of cross section \times length

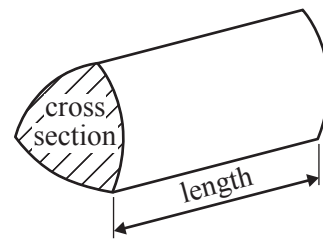

or $\sin \theta = \frac{\text{opp}}{\text{hyp}}$

$\cos \theta = \frac{\text{adj}}{\text{hyp}}$

$\tan \theta = \frac{\text{opp}}{\text{adj}}$

Circumference of circle = $2\pi r$

Area of circle = πr^2

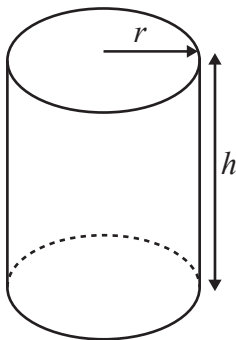

Volume of cylinder = $\pi r^2 h$

Curved surface area of cylinder = $2\pi r h$

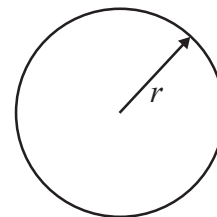

Answer ALL TWENTY THREE questions.

Write your answers in the spaces provided.

You must write down all the stages in your working.

1 The table shows the lengths of six rivers.

River	Length (km)
Mekong	4425
Yangtze	6380
Congo	4667
Amazon	6516
Nile	6695
Huang He	5464

(a) Which of these rivers is the longest river?

.....
(1)

(b) Write the number 4425 in words.

.....
(1)

(c) Write down the value of the 5 in the number 6516

.....
(1)

(d) Which number in the table is a multiple of 10?

.....
(1)

(e) The Ob-Irtysh river is 985 km longer than the Mekong river.

Work out the length of the Ob-Irtysh river.

..... km
(1)

(Total for Question 1 is 5 marks)



impossible

unlikely

likely

certain

(a) Write down a word from the box that best describes the likelihood of each outcome.

(i) In a week chosen at random, Wednesday will be after Tuesday.

.....

(ii) A person chosen at random will have a birthday in August.

.....

(2)

(b) James throws an ordinary fair dice.

(i) On the probability scale, mark with a cross (×) the probability that the dice will land on a number greater than 6

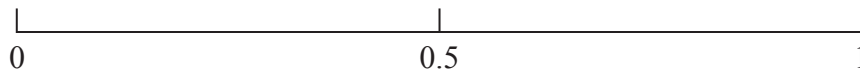

(ii) On the probability scale, mark with a cross (×) the probability that the dice will land on an even number.

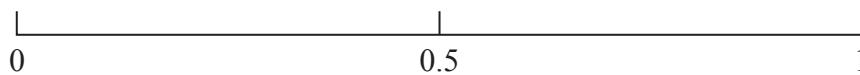

(2)

(Total for Question 2 is 4 marks)

Do NOT write in this space.



3 (a) Write down the mathematical name of this 3-D shape.

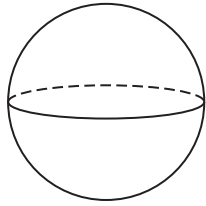

.....
(1)

(b) (i) Write down the mathematical name of this 3-D shape.

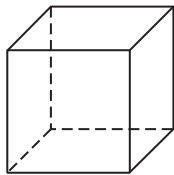

.....
(ii) How many faces does this shape have?
.....

(iii) How many vertices does this shape have?
.....

.....
(3)

(Total for Question 3 is 4 marks)

Do NOT write in this space.



P 4 4 6 1 2 A 0 5 2 0

- 4 The bar chart shows information about the number of barrels of oil produced per day in each of five countries.

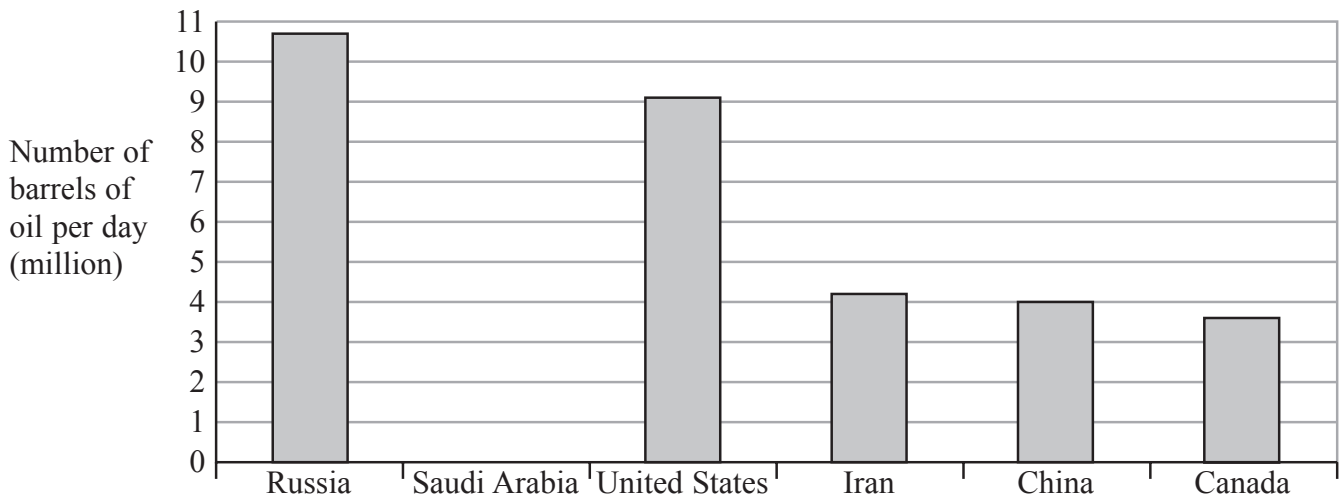

- (a) Write down the number of barrels of oil produced per day in China.

..... million
(1)

- (b) Write down the number of barrels of oil produced per day in Russia.

..... million
(1)

- (c) Which country produces 4.2 million barrels of oil per day?

.....
(1)

Saudi Arabia produces 9.6 million barrels of oil per day.

- (d) Draw a bar on the bar chart to show this information.

(1)

In the United States

72 000 barrels of oil are produced per day in the state of Utah.

18 000 barrels of oil are produced per day in the state of Michigan.

- (e) Find the ratio of the number of barrels of oil produced in Utah to the number of barrels of oil produced in Michigan.

Give your ratio in its simplest form.

.....
(2)

(Total for Question 4 is 6 marks)



- 5 (a) Write these numbers in order of size.
Start with the smallest number

5.6 5.04 4.6 4.56 5.46

.....
(1)

- (b) Write $7\frac{1}{2}$ as a decimal number.

.....
(1)

- (c) Shade 30% of this shape.

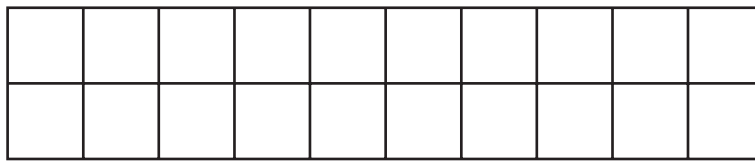

(1)

- (d) Write 40% as a decimal.

.....
(1)

- (e) Write 0.87 as a fraction.

.....
(1)

- (f) Write $\frac{9}{16}$ as a decimal.

.....
(1)

(Total for Question 5 is 6 marks)

Do NOT write in this space.



6 The diagram shows a quadrilateral $ABCD$ on a grid.

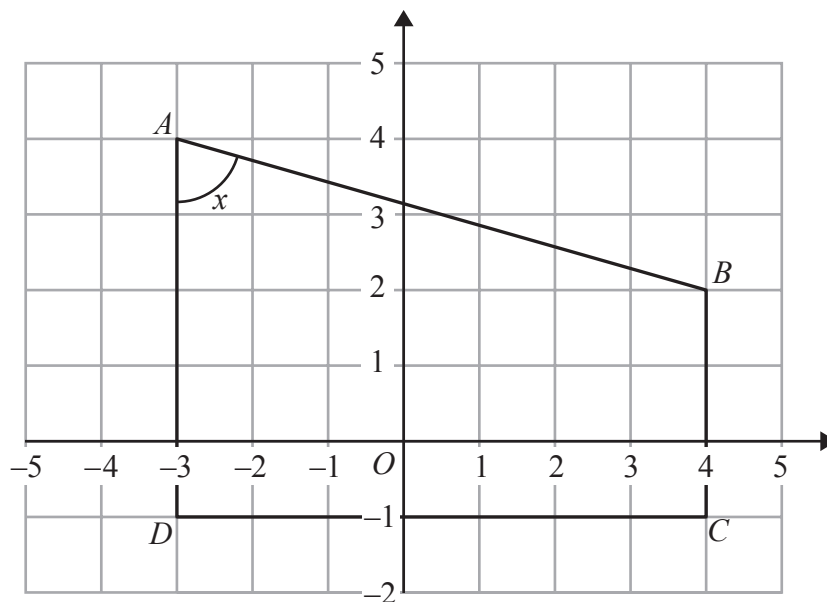

(a) Write down the coordinates of the point

(i) B (..... ,) (1)

(ii) D (..... ,) (2)

(b) Write down the mathematical name for the quadrilateral $ABCD$.

..... (1)

(c) (i) Write down the mathematical name for the angle marked x .

.....

(ii) Measure the size of the angle marked x .

..... (2)

(Total for Question 6 is 5 marks)



7 (a) Solve $5x = 20$

$x = \dots\dots\dots$
(1)

(b) Simplify $k + k + k + k + k$

$\dots\dots\dots$
(1)

(c) Simplify $8p + 4m - 5p + m$

$\dots\dots\dots$
(2)

(d) $T = 4x + 9y$

Work out the value of T when $x = -5$ and $y = 3$

$T = \dots\dots\dots$
(2)

(e) Factorise $c^2 - 5c$

$\dots\dots\dots$
(2)

(f) Simplify $d^5 \times d^7$

$\dots\dots\dots$
(1)

(Total for Question 7 is 9 marks)

Do NOT write in this space.



8 (a) The temperature in Moscow is -12°C .

The temperature in Rome is 15°C higher than in Moscow.

Work out the temperature in Rome.

.....
 $^{\circ}\text{C}$
(2)

(b) Work out

(i) $7 - (-9)$

.....

(ii) -6×5

.....
(2)

(c)

Signs + - × ÷

Write a sign in each box so that each of these statements are true.

(i) $3 \square 6 \times 4 = 27$

(ii) $3 \square 6 + 28 \square 4 = 25$

(2)

(d) Work out the cube of 5

.....
(1)

(e) Find the square root of 256

.....
(1)

(Total for Question 8 is 8 marks)



9 (a) On the rectangle, draw all the lines of symmetry.



(1)

(b) Here are four quadrilaterals.

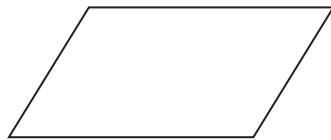

A

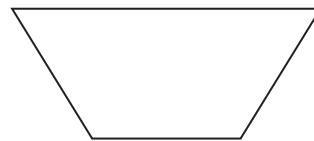

B



C

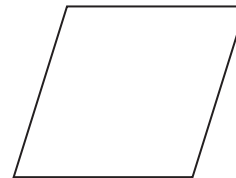

D

(i) One of these quadrilaterals has rotational symmetry of order 4
Write down the letter of this quadrilateral.

.....

(ii) One of these quadrilaterals has no lines of symmetry and rotational
symmetry of order 2
Write down the letter of this quadrilateral.

.....
(2)

(Total for Question 9 is 3 marks)

Do NOT write in this space.



10 A film started at 5 45 pm and finished at 8 10 pm.

(a) Write 5 45 pm as a time using the 24-hour clock.

.....
(1)

(b) Work out how long the film lasted in hours and minutes.

.....hoursminutes
(2)

(Total for Question 10 is 3 marks)

11 Becky counted the number of matches in each of 50 boxes.

The table shows information about her results.

Number of matches	Frequency
45	3
46	7
47	12
48	23
49	4
50	1

(a) Write down the mode of the number of matches.

.....
(1)

(b) Work out the range of the number of matches.

.....
(2)

(c) Work out the mean number of matches.

.....
(3)

(Total for Question 11 is 6 marks)



12

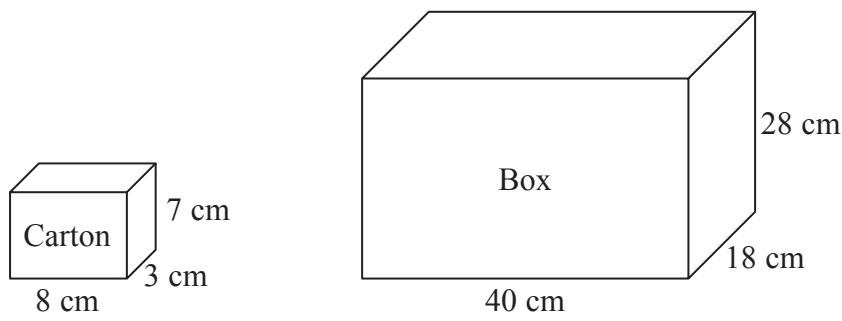

Diagram **NOT** accurately drawn

A carton measures 8 cm by 3 cm by 7 cm.
Cartons are packed into boxes.
A box measures 40 cm by 18 cm by 28 cm.

Work out the number of cartons that can completely fill one box.

.....
(Total for Question 12 is 3 marks)

13 (a) Work out $\frac{5}{9}$ of 72 kg.

..... kg
(2)

(b) Show that $\frac{1}{3} + \frac{4}{15} = \frac{3}{5}$

(2)

(Total for Question 13 is 4 marks)



14 A bag contains only red counters, blue counters and yellow counters.
The number of red counters in the bag is the same as the number of blue counters.

Mikhail takes at random a counter from the bag.
The probability that the counter is yellow is 0.3

Work out the probability that the counter Mikhail takes is red.

.....
(Total for Question 14 is 3 marks)

15

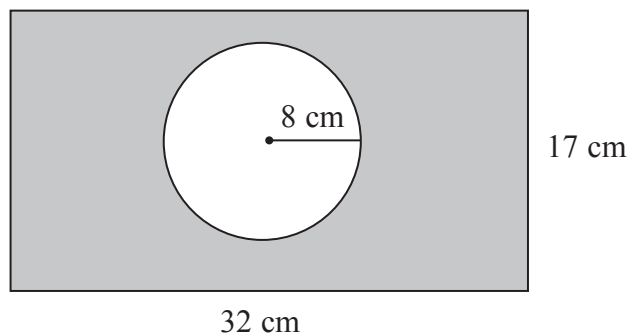

Diagram NOT
accurately drawn

The diagram shows a circle inside a rectangle.

Work out the area of the shaded region.
Give your answer correct to 3 significant figures.

.....cm²

(Total for Question 15 is 3 marks)



16 On the grid, draw the graph of $y = 3x - 4$ for values of x from -2 to 3

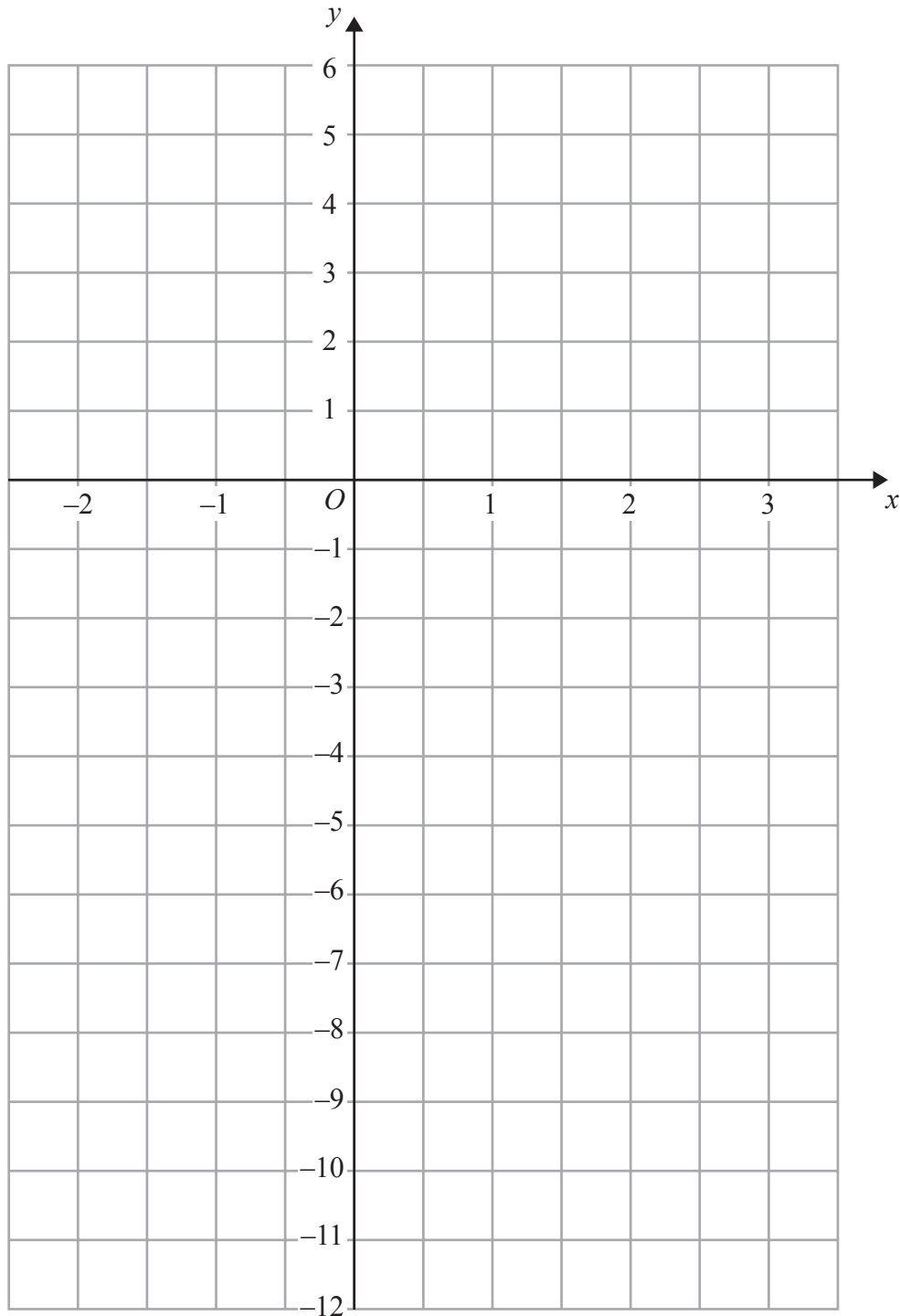

(Total for Question 16 is 4 marks)



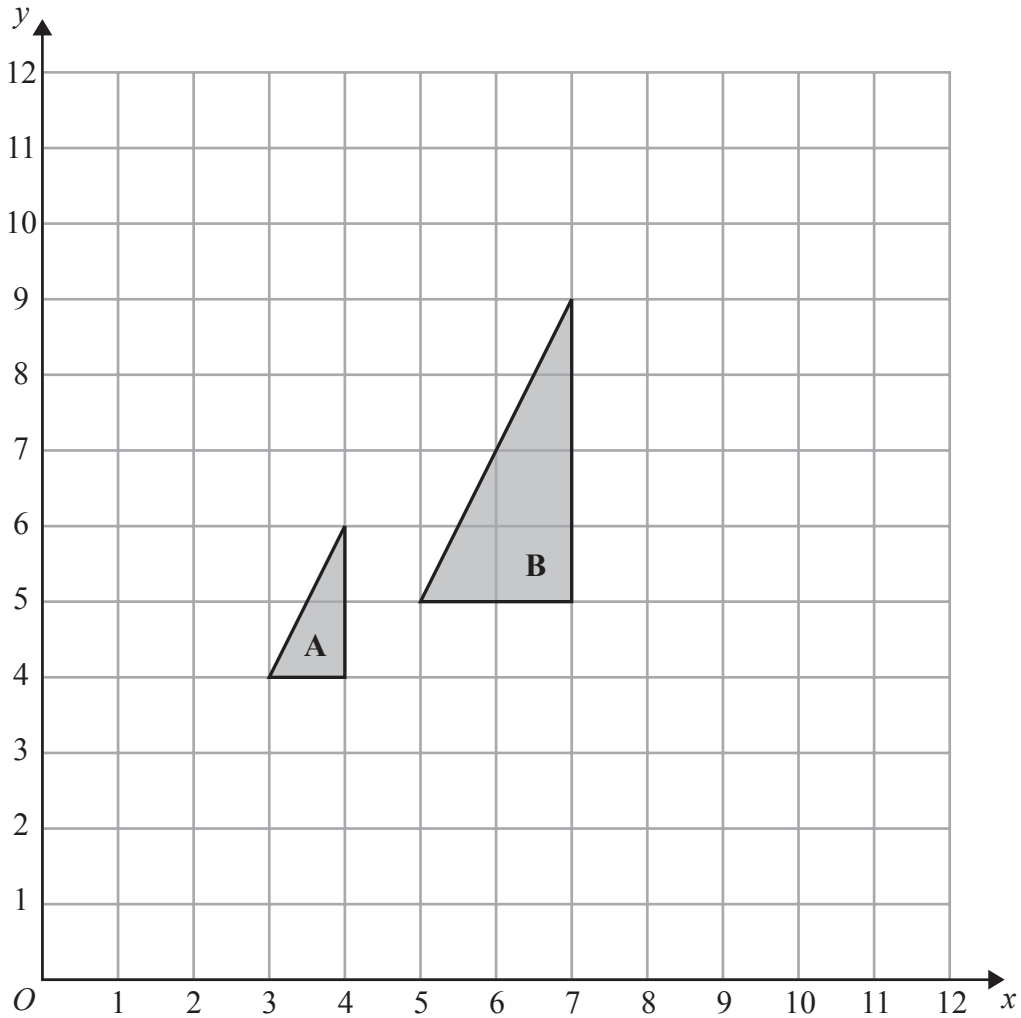

(a) Describe fully the single transformation that maps triangle A onto triangle B.

(3)

(b) On the grid, translate triangle A 5 squares to the right and 2 squares down.

(1)

(Total for Question 17 is 4 marks)

Do NOT write in this space.



18 $\mathcal{E} = \{\text{positive whole numbers less than 19}\}$

$A = \{\text{odd numbers}\}$

$B = \{\text{multiples of 5}\}$

$C = \{\text{multiples of 4}\}$

(a) List the members of the set

(i) $A \cap B$

.....

(ii) $B \cup C$

.....

(2)

$D = \{\text{prime numbers}\}$

(b) Is it true that $B \cap D = \emptyset$?

Tick (\checkmark) the appropriate box.

Yes

No

Explain your answer.

.....
(1)

(Total for Question 18 is 3 marks)

19 Lisa, Max and Punita share £240 in the ratio 3 : 4 : 8

How much more money than Lisa does Punita get?

£.....

(Total for Question 19 is 3 marks)



20 The diagram shows a triangle.

Diagram **NOT**
accurately drawn

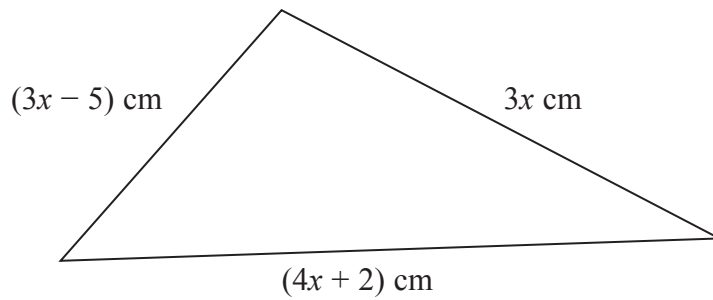

The lengths of the sides of the triangle are $3x$ cm, $(3x - 5)$ cm and $(4x + 2)$ cm.

The perimeter of the triangle is 62 cm.

Work out the value of x .
Show clear algebraic working.

$x = \dots\dots\dots$

(Total for Question 20 is 4 marks)



- 21 Three positive whole numbers are all different.
The numbers have a median of 8 and a mean of 6
Find the three numbers.

.....
(Total for Question 21 is 2 marks)

- 22 (a) Solve the inequality $3x + 8 < 35$

.....
(2)

- (b) Write down the inequality shown on the number line.

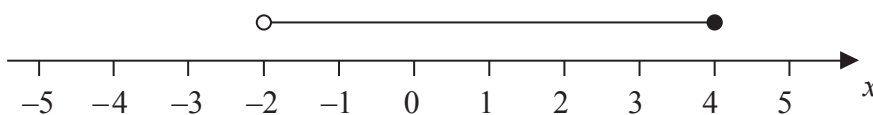

.....
(2)

(Total for Question 22 is 4 marks)



Diagram **NOT**
accurately drawn

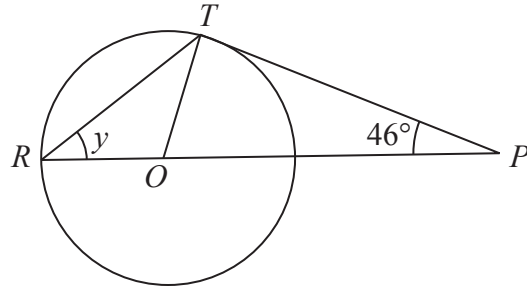

R and T are points on a circle, centre O .

ROP is a straight line.

PT is a tangent to the circle.

Angle $TPO = 46^\circ$

(a) Explain why angle $OTP = 90^\circ$

(1)

(b) Work out the size of angle y .

(3)

(Total for Question 23 is 4 marks)

TOTAL FOR PAPER IS 100 MARKS

